



# SERIES 180 SPRING ISOLATORS

CATALOG NO. 90A-651-E



Type "181"



Type "182"

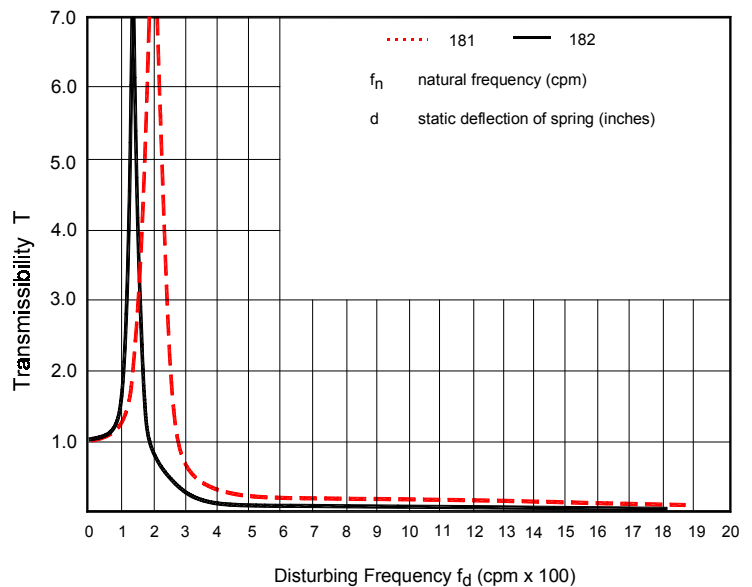

**Superior Isolation Efficiency:** Series "180" spring isolators feature static deflection from 1 to 2.7 inches to provide excellent isolation of vibrations over a wide frequency range.

**Safe And Compact Design:** Through-bolt and adjustable snubbers designs of series "180" spring isolators are ideal for internally mounted fans in large HVAC units. Low stress spring design increases service life.

**All Directional Design:** The type "181" and "182" models are designed to resist lateral and vertical loads of seismic zone applications.

**Wide Load Ranges:** Load capacities start from 50 lbs. to 1800 lbs. for each spring unit.

**Maximum Lateral Stability:** Large O.D. to operating height ratio increases spring stability.

## ACE MOUNTINGS CO., INC.

11 Cross Avenue  
South Amboy, NJ 08879  
Tel: (732)721-6200 Fax: (732)721-5005  
Email: [acemount@att.net](mailto:acemount@att.net)  
Website: [www.acemount.com](http://www.acemount.com)

# Dimensions • Load Rating

181

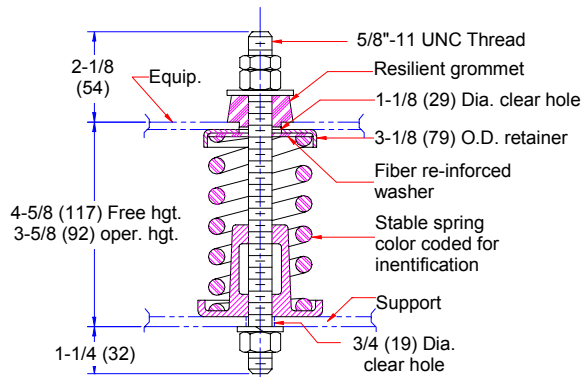

Size	Color of spring	Spring rate (Lbs/in)	Max. load (Lbs)	Lateral seismic load (G's)
A	Gray	100	150	4.6
B	Tan	200	260	2.65
C	Yellow	335	435	1.58
D	Green	500	550	1.25
E	Red	780	780	0.88
F	Silver	1070	1070	0.64
G	Brown	1400	1400	0.49
H	Black	1800	1800	0.38

182

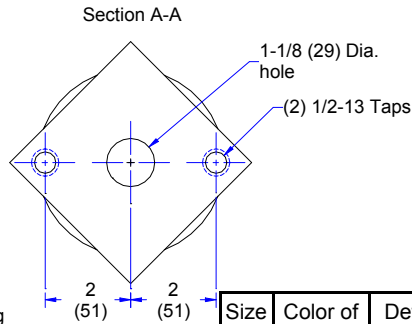
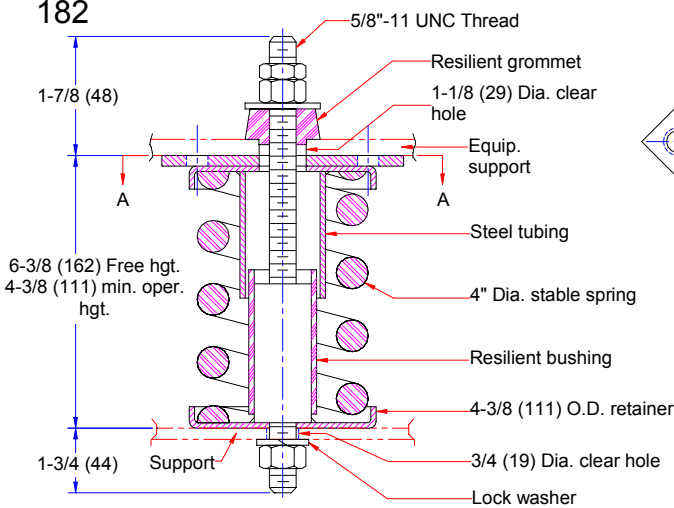

Size	Color of spring	Deflection (Inches)	Load range (Lbs)	Lateral seismic load (G's)
A	Gray	1.75-2.70	130-202	6.38
B	Tan	1.75-2.3	218-287	4.49
C	Yellow	1.75-2.35	306-411	3.13
D	Green	1.75-2.3	367-480	2.68
E	Red	1.75-2.17	481-596	2.16
F	Silver	1.75-2	612-700	1.84
G	Brown	1.75-2	743-850	1.51
H	Black	1.75-2	1050-1200	1.07

M 182

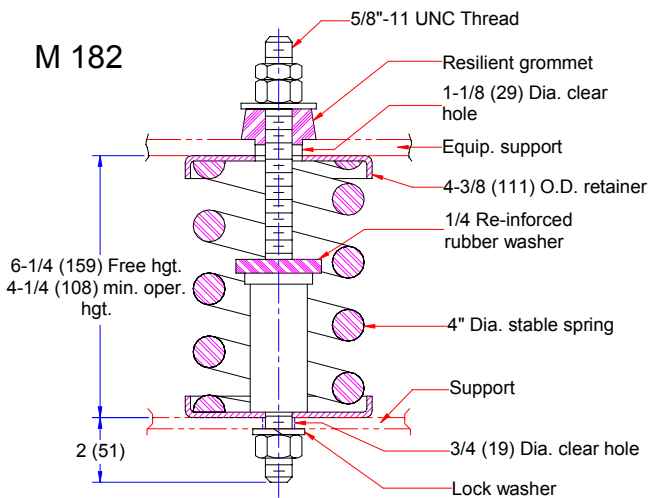

Size	Color of spring	Deflection (Inches)	Load range (Lbs)
A	Gray	1.75-2.70	130-202
B	Tan	1.75-2.3	218-287
C	Yellow	1.75-2.35	306-411
D	Green	1.75-2.3	367-480
E	Red	1.75-2.17	481-596
F	Silver	1.75-2	612-700
G	Brown	1.75-2	743-850

Note: All dimensions are in inches (mm).

# ACE MOUNTINGS CO., INC.

11 Cross Avenue  
 South Amboy, NJ 08879  
 Tel: (732)721-6200 Fax: (732)721-5005  
 Email: [acemount@att.net](mailto:acemount@att.net)  
 Website: [www.acemount.com](http://www.acemount.com)